



D. Marchiori

MPS46/56

Laboratory Air Data Test Sets

- Independent control of Altitude & Airspeed
- Exceeds RVSM accuracy, with 12 months recalibration period
- GPIB, RS232 and USB interfaces for ATE systems compatibility
- User programmable safety limits and multiple test programs
- Internal pumps, single channel & high flow rate variants
- 19 inch Rack mount 2U high



MPS46/56 Precision Laboratory Digital Air Data Test Sets

SUPPLYING AIR DATA TEST SETS TO THE WORLD

DMA traces its origins back to 1938, mainly as a test equipment manufacturer to support European aviation requirements. Today DMA supply precision Air Data Test Sets and other aviation ground support equipment to aircraft manufacturers, repair stations and operators throughout the world.

LABORATORY TESTER FOR DEMANDING APPLICATIONS

The MPS46 is a rack mount or table top digital technology Air Data Test Set incorporating many standard features normally found on more expensive test instruments. As well as the standard Static and Pitot twin channel MPS46 unit, a single Ps channel version is available as the MPS46M (mono). A twin channel version with internal pumps is available as the MPS46P. The instruments are housed in a standard 19 inch by 2U enclosure, resulting in a compact rugged design.

EASY INTUITIVE INTERFACE

Using logical key press routines the MPS46 is easy to use by both beginners and experts. Testing and trouble shooting can be performed via the keypad or adjacent full colour touch-screen display. Optionally remote control can be via GPIB, USB, RS232 or

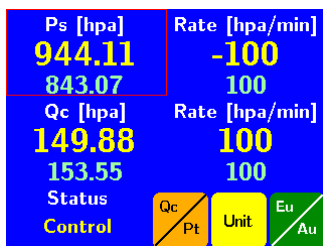

Ethernet. All the important air data functions are simultaneously displayed on all interfaces, constant screen or menu changes are not required. Readings of both commanded and measured test values are displayed.

Laboratory testing can also be performed by a PC, including the MPSPMON Panel PC. The comprehensive manuals include all the control instructions. ADWIN36 software is available as a ready-to-run PC based interface.

ACCURACY ACHIEVED BY THE END OF SELF TEST

Two high performance piezo resistive absolute transducers are utilised for the static and pitot channels. Pressure and temperature characterisation is applied to the sensors ensuring very high accuracy is achieved at all operating pressure values, without any significant warm-up time.

PRESSURE AND VACUUM SUPPLIES

The MPS46 requires external pressure and vacuum supplies connected via appropriate fittings on the rear panel. DMA do manufacture a rack mounted Pressure and Vacuum Unit, see the EPSR2 data sheet for details. The MPS46P is also available. This is a version of the MPS46 with internal, small capacity, pumps. See details on the Standard Specification listing.

AUTOMATED CALIBRATION

Calibration, performed by software, is fast and simple since no mechanical adjustments are required. Calibration factors are password protected for security. The resultant accuracy of the sensors exceeds the RVSM industry requirements.

FLEXIBLE MULTIPLE LINE SWITCHING OPTION

The MPS46 as standard provides 2 connectors for altitude and 2 for airspeed on the instrument front panel. and on the rear panel are further single ports for Ps and Pt.

An optional multiple line switching capability permits fast and safe isolation of 3 lines per channel by means of isolation valves to isolate leaking channels. Control is possible from any of the local or remote user interfaces. Combinations of line switching are also possible for numerous fault finding routines.

LOW POWER CONSUMPTION FOR HIGH RELIABILITY

Careful consideration during the design ensures low power consumption giving minimal internal temperature rise which consequently results in high reliability: typically 60 W power consumption from the AC line.

BUILT IN SAFETY LIMITS FOR UUT PROTECTION

The MPS46 is designed for maximum safety during testing. Key DMA design features protect both the test set and the systems under test. Negative Qc, a pressure condition of Ps greater than Pt, is prevented in both manual and automatic operation. If AC power is lost then the Unit Under Test (UUT) is safely isolated and can be manually vented preventing instrument and test set damage.

Numerous pre-set factory or user programmed safe limits are provided to prevent damage to the UUT. These limits can be modified by the user either temporarily or permanently, with password protection if desired.

MPS46 VARIANTS

THE MPS46P includes internal pressure and vacuum pumps providing a totally self contained air data test set with no requirement for external pumps, still housed in a 2U enclosure. The MPS46P provides the same range as many flight line testers, with greater accuracy. The internal low noise diaphragm pumps have a 5000 hours warranty and run only when the system requires extra supplies. Where higher levels of altitude and airspeed are required, above the standard MPS46P civil capability, connectors for external Pressure and Vacuum are located on the rear panel. A pump unit such as the EPSR2 can be used for the higher ranges.

The MPS46M is a single channel version of the MPS46 providing only the Static absolute capability of the standard instrument. The MPS46M requires external pumps but is also available with internal pumps as the MPS46PM.

The MPS46H is a high flow rate version of the MPS46, still housed within a 2U high rack unit. The EPSR2 is an ideal external pump unit for the MPS46H.

For working into very large volumes or at higher rates, the MPS56 is an MPS46 fitted with larger control valves and repackaged into a 3U enclosure. The table on the facing page compares the capabilities of the MPS46 variants.

LINE SWITCHING UNIT DMMI3

The DMMI3 is a multiple isolator for use with the MPS46 in ATE systems. Each of the front panel outputs can be individually switched either manually or under remote control (Ethernet, USB, RS232). 8 outputs are provided for each channel (Ps and Pt) with the Ps and Pt inputs being on the rear panel. At only 2U high this line switching unit provides comprehensive features whilst using minimal system rack space.

MPS46 FRONT PANEL

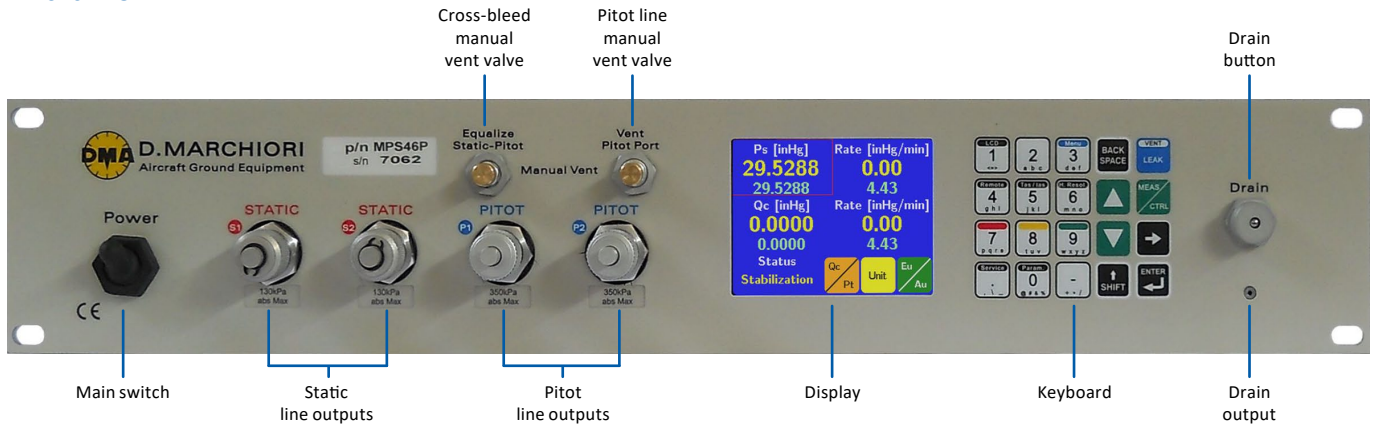

MPS46 REAR PANEL

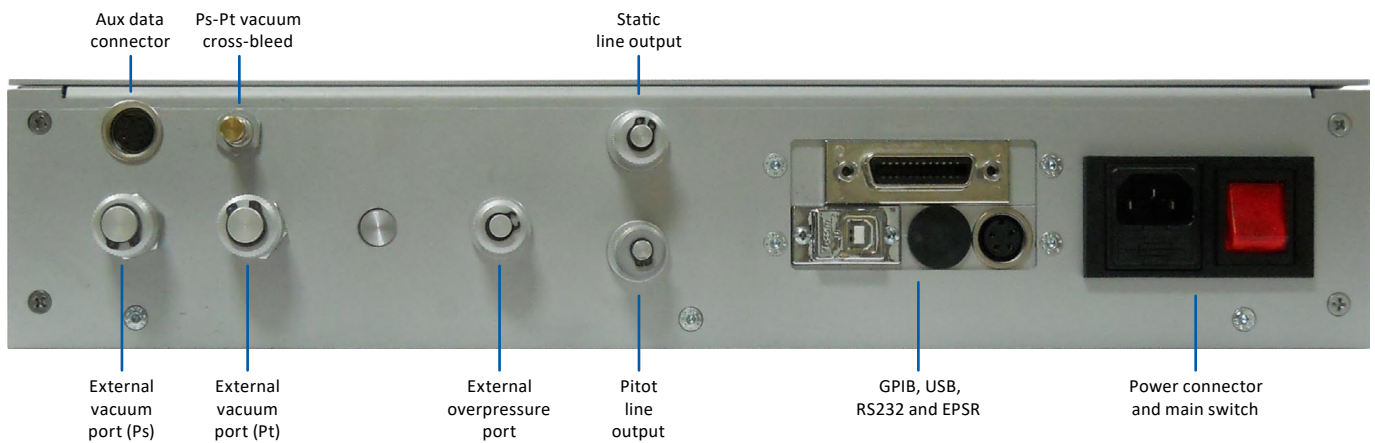

DMMI3 FRONT & REAR PANELS

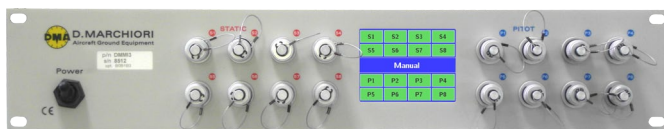

MPS46 VARIANTS

Model	Height	Channels	Pumps	ROC (ft/min)	Volume (Ps + Pt)
MPS46	2U	Ps + Pt	External ^[1]	6,000	2 L + 1.3 L
MPS46P	2U	Ps + Pt	Internal	6,000	2 L + 1.3 L
MPS46M	2U	Ps	External ^[1]	6,000	2 L
MPS46PM	2U	Ps	Internal	6,000	2 L
MPS46H	2U	Ps + Pt	External ^[1]	15,000	2 L + 1.3 L
MPS56	3U	Ps + Pt	External ^[2]	10,000 ^[3]	10 L + 7 L

¹ Recommended external pump for MPS46 and MPS46H is EPSR2

² Recommended external pump for MPS56 is EPSR3

³ Achievable rate - please specify your particular high rate requirements when ordering

MPS56





MPS46/56 Standard Specifications

	PARAMETER		RANGE		RESOLUTION		ACCURACY [7]
			MEASURE	CONTROL	MEASURE	SETPOINT	
STATIC	Altitude	Standard (ft)	-7,500→100,000	-7,500→80,000 [1]	1	1	± 2 @ SL ± 4 @ 30,000 ± 8 @ 50,000
		Option J3 (ft)	-7,500→100,000	-7,500→100,000 [2]			
		Option J4 (ft)	-15,500→100,000	-15,000→80,000 [5]			
	Vertical speed	Standard (ft/min)	0→6,000	0→6,000	5 @ < 3,000 [4]	1	± 1% of setting
High rate option [3] (ft/min)		0→60,000	0→60,000				
Static	Standard (inHg abs) (hPa abs)	0.3→38 10→1300	0.8→38 [1][5] 27→1300	0.0001 0.002	0.0001 0.002	± 0.0013 @ 3.5, ± 0.002 @ 30 ± 0.045 @ 100, ± 0.07 @ 1000 ± 0.01 @ 50 inHg ± 0.34 @ 1700 hPa	
	Option J4 (inHg abs) (hPa abs)	0.3→50 10→1700	0.8→50 [5] 27→1700				
PITOT	Airspeed	Standard (kts)	10→1,000	10→1,000 [2][6]	1 @ < 50 0.1 @ > 50	0.1	± 0.8 @ 50 ± 0.1 @ > 500 ± 0.03 hPa
		Ultra low speed function (kts)	2→200	2→200			
	Airspeed slew rate (kts/min)	0→900	0→900	10	10	± 10 ± 1% of setting	
	Mach No. (mach)	0→6	0→6	0.001	0.001	< ± 0.002	
	Pitot (inHg abs) (hPa abs)	0.3→103 10→3500	0.3→103 [2][6] 10→3500	0.0001 0.005	0.0001 0.005	± 0.0025 @ 3.5, ± 0.004 @ 30 ± 0.006 @ 80 inHg ± 0.085 @ 100, ± 0.14 @ 1000 ± 0.2 @ 2700 hPa	
Engine Pressure Ratio (EPR)	1→2.5 @ SL	1→2.5 @ SL	0.001	0.001	0.001		

Notes: Control capability on all load volumes: Static: 0 to 2 L (125 cu. in.), Pitot: 0 to 1.3 L (80 cu. in.). Larger volumes acceptable

¹ Achievable with internal pumps on MPS46P

² Requires external pumps

³ High rate achievable into small system volumes

⁴ Selectable to ± 1 ft/min

⁵ Option J3 extends control to 100,000 ft (10 hPa, 0.3 inhg). Option J3 can be combined with option J4.

⁶ Internal pumps only achieve 850 kts (2600 hPa, 77 inhg)

⁷ Total accuracy includes all metrological uncertainty contributions for the pressure measured. Metrological data has full traceability with International accredited Labs.

STANDARD TEST FUNCTIONS

- Automatic leak check
- Controlled venting to ambient
- Altitude/airspeed input *
- Static/dynamic(Qc)/total pressure input *
- Altitude/airspeed rates input*
- Mach Number input*
- EPR generation*
- TAS / IAS toggle, TAS temperature correction*
- Altitude offset correction
- 30 user test programmed profiles of 26 steps each
- Ultra low speed (2 to 200 kts) for improved accuracy and stability*
- Audible indication when approaching set point

* Note: MPS46M offers only Static/Altitude functions

DISPLAY AND KEYPAD

Integral display and keypad in splash proof and shock protected front panel.

Back lit colour LCD displays all test parameters.

DISPLAYED UNITS

Altitude: ft, m, hm
Airspeed: kts, km/h, mph
Pressure: inHg, hPa, kPa, Pa, psi, mmHg,
inH₂O 4°C

CALIBRATION

One year interval, performed using software.

PHYSICAL SPECIFICATIONS

Weight MPS46: 10 kg. (22 lbs.)
Weight MPS46P: 12 kg. (27 lbs.)
Weight MPS56: 9 kg. (20 lbs.)
Dimensions (MPS46): W 483 x D 280 x H 89 mm
(W 19 x D 11 x H 3.5 in.)
Connections: AN-4 (Ps), AN-3 (Pt)
AN fittings with o-rings allow finger tight connections.

ENVIRONMENTAL

Temperature range
Operating: 0°C to +50°C
Storage: -20°C to +70°C
Front panel splash-proof.
CE compliant.

POWER SUPPLY

Universal supply: 90-240 VAC; 50-400 Hz. 60 W

WARRANTY

Unit: 2 Years

SOFTWARE LIBRARY

Command Set (RS232, USB, GPIB, Ethernet)
Customer interface software for modular ATE applications.

OPTIONS

- B1** USB port ⁵
 - B3** Ethernet port ⁵
 - B4** IEEE488 GPIB control (RS232 is standard) ⁵
 - B5** ARINC429 monitoring interface ⁵
 - B7** Gray Code Altitude Device Read-out ⁵
 - E2** 2+2 Multiple Pitot and Static internal isolators controlled from keypad. ⁵
 - E3** 3+3 Multiple Pitot and Static internal isolators controlled from keypad. ⁵
 - F0** ADWIN36 PC Control software
 - J3** Ps control extended to 10 hPa, 100,000 ft ⁴
 - J4** Ps control extended to 1700 hPa, -15,000 ft ⁴
- ⁴ Options J3 & J4 require external pumps and can both be combined if required
⁵ Refer to DMA-Aero for option combination limitations
– Custom Pitot/Static connections available

ASSOCIATED PRODUCTS

DMMI3 Line switching unit.
MPSMON desk mounted remote control unit
EPSR2 & EPSR3 External rack mount vacuum/pressure supply
PAMB11 Pressure indicator/transfer standard

Ongoing development results in specifications being subject to change without notice



EvoMesure

170 Av des Cocardières,
34160 Castries – Montpellier
France

Email: contact@evomesure.com
Téléphone: +33(0)9 52 08 08 09

www.EvoMesure.com



The activities described on this data sheet are not certified by ACCREDIA
<http://www.dma-aero.com/eu/dmarchiori-dma-accreditation>

Representative